

SERVICE MANUAL

STEREO CASSETTE TAPE DECK

SANSUI SC-3300 SC-3330



SPECIFICATIONS

Track	4-Track (2-Channel Stereo)
Tape speed	4.8 cm/sec. (1-7/8 ips)
Heads	Record/Playback: FH Head Erase: Double Gap Ferrite Head
Motor	Capstan: Electronically Controlled DC Motor Reels: DC Motor
Wow and flutter	within 0.04 % WRMS
Fast wind time	approximately 70 seconds (C-60)
Frequency response (Record/Playback)	
Normal Tape (LH) (-20 VU)	20 to 16,000 Hz (20 to 15,000 Hz ± 3 dB)
Metal Tape (-20 VU)	20 to 18,000 Hz (20 to 16,000 Hz ± 3 dB) (0 VU) 20 to 13,000 Hz ± 3 dB
Signal to noise ratio (Record/Playback)	
Metal Tape (without Dolby Noise Reduction Effect)	better than 59 dB (weighted)
(With Dolby Noise Reduction)	better than 69 dB (above 5 kHz)
Erasure factor (Metal Tape)	more than 70 dB at 1,000 Hz
Input sensitivity and impedance (0 VU, 1,000 Hz)	
MIC	0.3 mV/200 Ω ~ 5 k Ω
LINE IN (REC)	70 mV/100 k Ω
Output level (0 VU, 1,000 Hz)	
LINE OUT (PLAY)	390 mV
PHONES	65 mV/8 Ω
Bias frequency	85 kHz
Power requirements	
Power voltage	100, 120, 220, 240 V (50/60 Hz)
For U.S.A. and Canada	120 V (60 Hz)
Power consumption	26 W (rated)

Dimensions

<SC-3300>

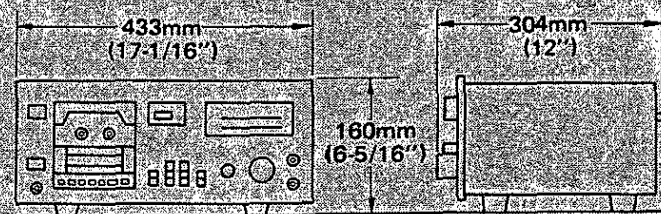

<SC-3330>

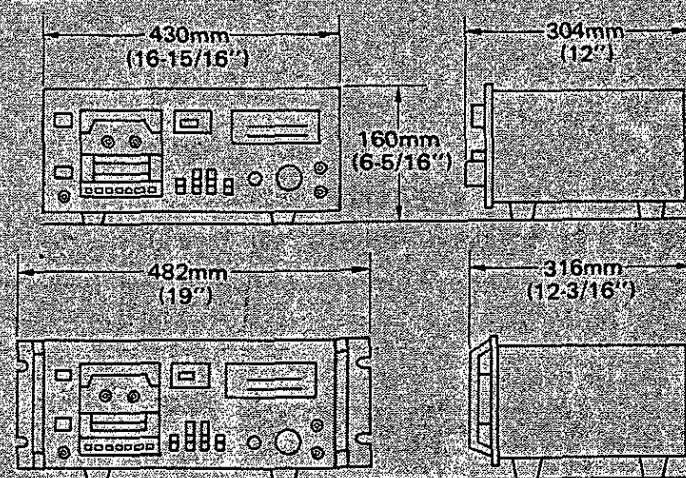

Weight	<SC-3300>
	7.4 kg (16.3 lbs.) net
	8.5 kg (18.7 lbs.) packed
	<SC-3330>
	8.15 kg (18.0 lbs.) net
	9.5 kg (20.9 lbs.) packed

*Design and specifications subject to changes without notice for improvements.



SANSUI ELECTRIC CO., LTD.

213

1. BLOCK DIAGRAM

1-1. Playing Operation (L-CH)

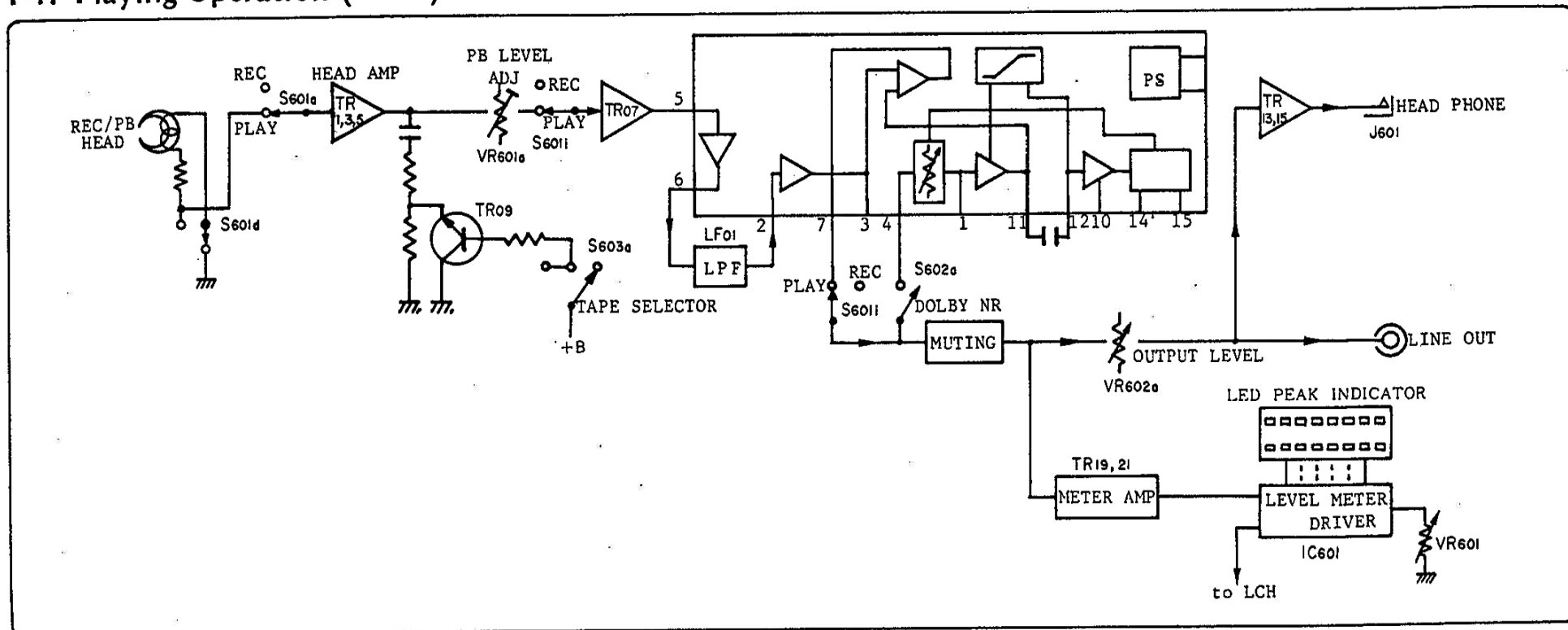

1-2. Recording Operation (L-CH)

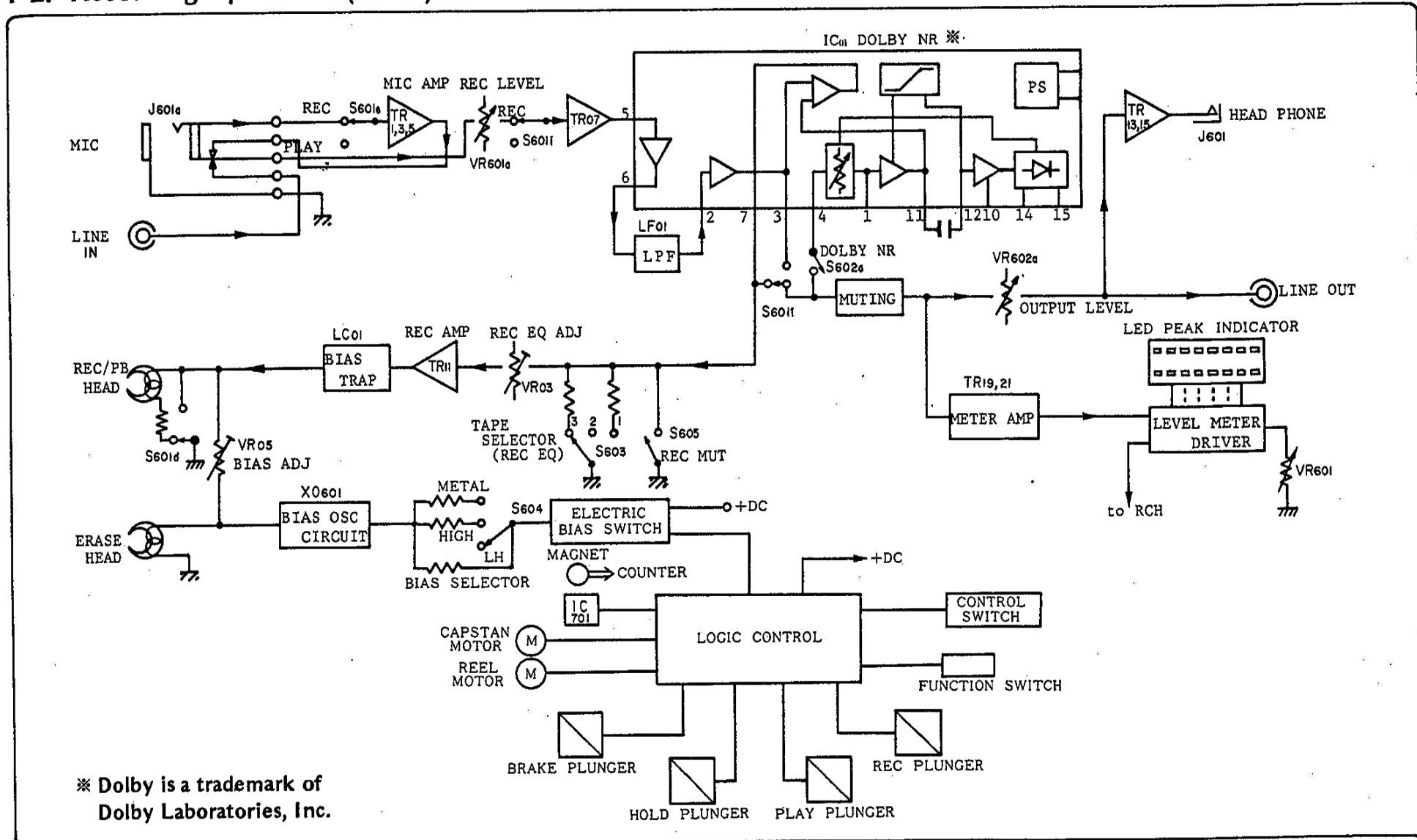

2. OPERATION

2-1. Operation of Mechanical Section (See Fig. 2-1, 2-2)

1: Release of Brake and Operation of Hold Lever

1) When either of the control buttons PLAY or REC, is depressed, the play plunger (C) turns on, causing the head base to lift up. This, in turn, causes the brake lever to lift up to release the brake.

2) When one of control buttons FF, REW and LEAD IN, is depressed, the brake plunger is turned on, causing the brake lever to lift and the brake to be released.

3) Since the hold lever moves inward in all modes other than in STOP (because the hold plunger (A) is "ON"), the cassette half is held by hold lever.

2. PLAY Operation

- 1) When the cassette half is set on the holder, the cassette play sensor is lifted up, causing the half switch to turn on. In this mode, the capstan motor starts rotating.
- 2) This torque of the capstan motor is transmitted to the capstan belt, capstan flywheel and capstan in that order.
- 3) When the play plunger (C) turns on, the head base rises, causing the pinch roller to be pressed against capstan and the tape to start travelling. At the same time, when the head base rises, the tension arm ass'y moves down in order of "X" "Y" "Z", and then presses against the take-up ass'y, transmitting the revolution of the motor to the take-up ass'y. The tape is taken up as a result.

3. REC Operation

- 1) The fundamental operation is quite similar to the play operation. When the cassette half is set on the holder, the REC sensor lever is lifted UP, causing REC sensor switch to turn on. By this, the logic circuits is enabled to perform REC operation.
- 2) When the REC button is depressed, the REC plunger turns on, causing the PLAY/REC amplifier circuit to be switched over to REC.

4. FF Operation

- 1) To depress FF button causes the brake plunger (B) to turn on so that the brake is released, simultaneously the F.R. idler to be

lifted up and to be pressed against the shaft of the reel motor. (Point G)

- 2) In the F.F. mode, the reel motor rotates at high speed. This torque is transmitted to the F.R. idler.
- 3) The F.R. idler moves to the left and right centering fulcrum H. When the rotation of the reel motor is transmitted to the F.R. idler, the idler moves rightward centering the fulcrum, causing it to press against the take-up ass'y and transmit the rotation.

5. REW Operation

- 1) The fundamental operation is quite similar to the F.F. operation. However, as the counterclockwise rotation of the reel motor is transmitted to the F.R. idler, the F.R. idler moves leftward centering the fulcrum and presses against the take-up ass'y to transmit the rotation.

6. Roller Back Tension

- 1) The rotation of the supply ass'y is transmitted to the back tension roller by means of the back tension belt. In conventional method to apply back tension, the tension is varied because the diameter of the rest tape rolled is changed. However, in the "roller back tension system" the constantly stabilized back tension can be applied since the system is utilizing the roller's friction of rotation. Therefore extremely smooth feed-out of tape and improvement of wow & flutter can be realized.

Fig. 2-1

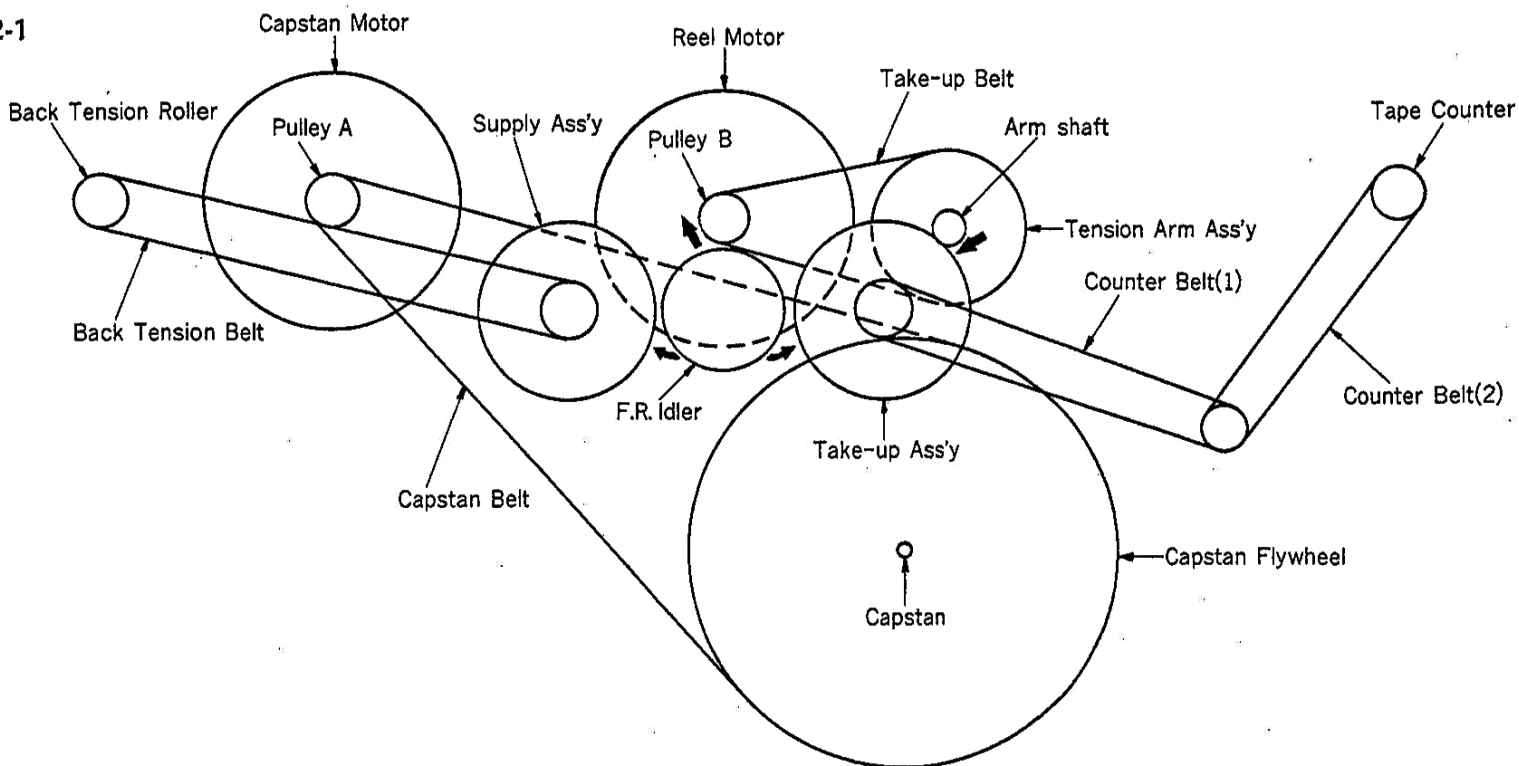
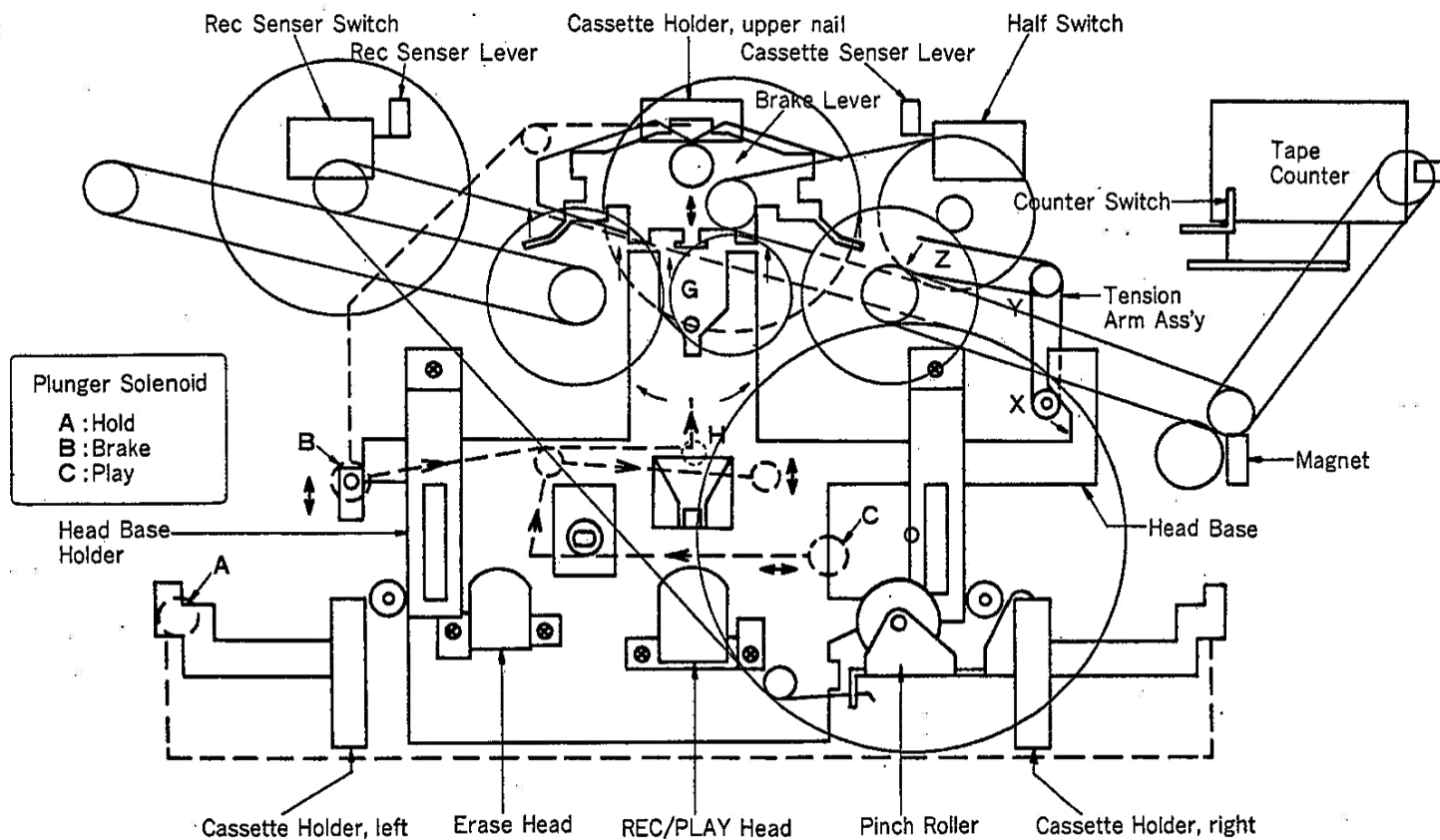

Fig. 2-2



2-2. Operation of Electric Circuits (Refer to block diagram and schematic diagram.)

1. Function and Operation of C-MOS LSI Employed in Logic Control Circuit

In these models, Full Logic Feather Touch Control is realized by using a logic control circuit whose main components are C-MOS LSI (Model TC9121P) and plunger solenoids.

The function and operation of the TC-9121P are as follows:

- Regarding the respective modes, operation is actuated when the LSI input is dropped instantaneously to the L-level. The operation is sustained until the set is changed over to next mode.
- A circuit preventing troubles caused by multiple-pushing of input keys is provided in the LSI. (Refer to Table Fig. 2-4.)
- Although the mode of PLAY, REC, REW, F.F. and MUT output terminals of LSI whether H or L can be changed directly, output is not appeared for approximately 0.5 second in order to protect the tape and the set's mechanisms. Terminals other than those just stated start operating immediately. For example, if the PAUSE mode is released either in the REC PAUSE mode or PLAY PAUSE mode, each output changes over immediately when the PAUSE button is depressed. The stop duration of operations is determined by the C and R connected to the OSC terminal.
- When power is switched on, the mode is shifted to "STOP" automatically.
- Automatic recording and automatic playback based on the use of a timer are possible.

Fig. 2-3 Top view & pin function of IC TC-9121P

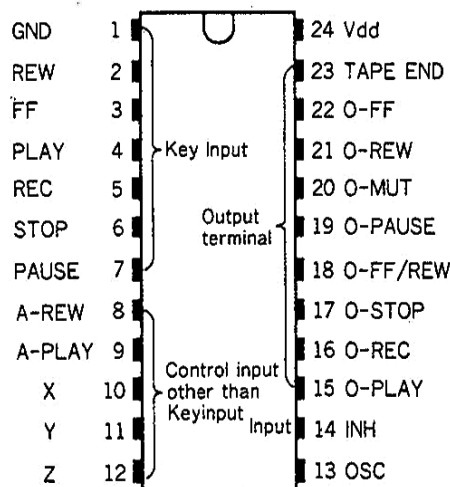

2. Operation of Logic Control Circuit

1) PLAY operation

- When the PLAY button is depressed, the voltage level of 0-STOP is shifted from "L" to "H". The hold plunger solenoid turns on as a result.
- After the lapse of approximately 0.5 second following the turn-on of hold plunger solenoid, the level of the 0-PLAY is shifted from "L" to "H". This causes the TR621 to turn on and the PLAY plunger solenoid successively is switched on.
- In addition to this, TR612 and TR606 also turn on when the level of the 0-PLAY changes to "H". When TR612 turns on, the reel motor starts rotating. When TR606 turns on, the level of Pin 13 of the flip-flop circuit composed of IC605 a and b change from "H" to "L". The level of Pin 11 of the flip-flop circuit changes from "L" to "H". As a result, TR604 is switched on and the PLAY indicator LED (LED601) starts glowing.

2) REC operation

- When the cassette half is set on the holder, the REC sensor switch automatically turns on. Further, while the REC key is depressed TR602 turns on, therefore causing the REC INPUT terminal to shift to the L-level.
- Following this, when the PLAY key is depressed, REC operation is performed. In the case the keys are operated in the reverse order, the operation of the REC key becomes ineffectual as

- Owing to the large current capacity of LSI, the control of the motor and plunger is easier. The LEDs indicating the respective modes can be lighted up directly.

Fig. 2-4 Mode produced by multiple-pushing of keys.

Key Input	Other Key Input	Output Mode
STOP	REW, FF, PLAY, REC, PAUSE	STOP
FF	REW, PLAY	STOP
	REW, PAUSE	FF
REW	FF, PLAY	STOP
	REC, PAUSE	REW
PLAY	PAUSE	PLAY PAUSE
REC	PLAY	REC
	PAUSE	PAUSE
	PLAY & PAUSE	REC PAUSE

Example: If, the F.F. Key and REW Key are depressed together, the output mode will change to "STOP". On the other hand, when the REC and PLAY keys are depressed together, the output mode becomes "REC".

Fig. 2-5 Mode of each output terminal for each key input (The "O" mark indicates the H-level output.)

Pin No.	Key Input Output	Key Input					PAUSE		
		STOP	FF	REW	PLAY	REC/PLAY	STOP	PLAY	REC/PLAY
15	O-PLAY				O	O			
16	O-REC					O			O
17	O-STOP		O	O	O	O	O	O	O
18	O-FF/REW		O	O					
19	O-PAUSE						O	O	O
20	O-MUT	O	O	O			O		
21	O-REW			O					
22	O-FF		O						
23	TAPE END	O	O	O	O	O	O	O	O

Note: The output of 0-FF/REW has the function of accelerating the motor speed in F.F. and REW operation, and at the same time, of preventing the PLAY indicator LED from lighting up.

TR603 turns on before TR602 does.

3) PAUSE operation

- When the PAUSE key is pushed, the level of the 0-PLAY is shifted to the L-level, causing the PLAY plunger to be released. (Refer to Table 2-5)
- Since Pin 1 of IC604 (AN6250) is shifted to L-level to change 0-PAUSE level to H from L, the output of Pin 6 does not change although rotation detecting pulses applied to Pin 2 from tape counter are stopped.

4) F.F. and REW operation

- When the F.F. key is operated the level of 0-F.F. becomes to "H" from "L", causing the brake to be released and TR613 to turn on at the same time.
- As a result, the level of the 0-F.F./REW is shifted from "L" to "H", causing TR609 to be turned on. By this, the speed of motor is accelated since the voltage of reel motor is increased that FF operation is carried out. Further, as the 0-FF/REW (when at the H-level) makes the level of Pin 9 of the flip-flop circuit (IC605 a & b) from "H" to "L", the level of Pin 11 becomes "L". Hence, the PLAY indicator LED is not lightened.
- Simultaneously with the push of the F.F. key, the level of the 0-MUT is changed from "L" to "H", causing the muting circuit

to be activated to cancel the cueing sounds which are being generated during this time.

- When the REW key is depressed, the level of 0-REW is shifted from "L" to "H" so that TR602 turns on. As a result, the reel motor turns in the direction opposite to that when the F.F. key is pushed. The operation except above is the same as F.F. operation.

5) AUTO STOP operation

- AUTO STOP operation are carried out through the operation of the IC604 (AN6250).

- During tape travel, the level of Pin 1 of the IC604 is shifted to the "H" level, and the output of IC604 is determined by the ROTATION DETECTING pulse of Pin 2.

- When the whole reel of tape has been taken up and the ROTATION DETECTING pulse stops, the level of Pin 2 is brought back again to "L". By this, after counting 384 pulses generated by internal OSC, IC604 shifts the level of Pin 6 to "L".

As the "L" level signal of Pin 6 passes through the differential circuit of R629 and C611, and instantaneously makes the level of "Z" terminal L, the mode is changed over to "STOP".

6) TIMER PLAY/TIMER REC operation

- In order to ensure that the LSI TC9121P (IC603) is brought automatically to the STOP mode upon switch-on of power, the LSI TC9121P is given a time constant by connecting C606 between the STOP terminal of the key input and the ground. This causes a delay in the rise of the STOP terminal voltage, compared with the rise of the power supply voltage. As a result the mode is brought to one equivalent to that when the STOP key is depressed.

Because of this, the circuit functions to prevent erroneous operations occurring as a result of, for example, the unbalance in the rise time caused by the time constant in the logic circuit.

- At the moment the TIMER PLAY switch as well as the power switch is turned on, the TR614 is off state. Furthermore, the levels of Pins 1 and 2 of the IC605C are brought to "H", and that of Pin 3 is "L".

- The base voltage of TR615 reaches its "ON" voltage after the lapse of a certain time determined by the time constant of R635 and C615. As a result, the level of Pin 2 of IC605C is shifted to "L".

- When the level of Pin 2 of IC605C is shifted to "L", the level of Pin 3 is brought to "H". The H-level signal of Pin 3 passes through the differential circuit of R632 and C613, and then instantaneously makes TR614 turn on. The signal further passes through the TIMER PLAY switch, causing the level of the PLAY terminal to shift to "L".

- Similar to TIMER PLAY, in the TIMER REC operation, the REC terminal and PLAY terminal are controlled by TR614.

7) TAPE LEAD IN operation

- By making use of the IC601 (one-shot multi-vibrator IC), F.F. operation is carried out for a certain duration determined by the time constant of C601 and R601.

- When the TAPE LEAD IN switch is depressed, C603 is discharged. This brings the level of the F.F. terminal to "L". As a result, F.F. operations is carried out.

- Simultaneously with the turn-on of the TAPE LEAD IN switch, the level of IC601's output terminal, Pin 1, is shifted over from "H" to "L".

After holding the "L" level for the duration determined by the time constant of C601 and R601, the level of IC601's output terminal, Pin 1, is shifted over to the H-level.

This change in Pin 1's level passes in the form of signal through the differential circuit of R604 and C601 and instantaneously makes TR601 turn on. Consequently, the STOP terminal of IC603 is shifted from "H" to "L", bringing the mode to "STOP"

- The duration of TAPE LEAD IN is determined by the time constant of C601 and R601. TAPE LEAD IN operation is not only took place at the start of the tape but also performed at any desired position.

3. Operation of Peak Meter Circuit

The peak meter circuit of these models are composed of 2-color, 16-element LEDs, IC and periphery circuits. Fig. 2-8 shows the circuit configuration. The basic operation is as follows: In accordance with the levels of the input signals that are fed in from the IC's Pins 2 (R-ch) and 3 (L-ch) into the LED drive circuit (composed of a reference voltage, differential amplifier and transistors), LEDs in a number of somewhere between 1 and 16 are caused to illuminate. The LED indicator circuit adopts the dynamic lighting system. As can be seen from Fig. 2-8, in this dynamic lighting system, the LEDs for the L-ch and those for the R-ch are light up in an alternating manner at a 200 Hz period, by means of internal oscillator and switching circuit (LA and RA) of IC. In reference to Fig. 2-6, when pulse A is applied to switching transistors (LA, RA), the LA output turns on. As a result, transistor TR01 on G-1265 turns on. By this, the collector voltage of TR01 is rised and making LEDs in the number (1 ~ 16), that corresponds to the input signal levels, light up. When pulse B is applied, the LEDs of the R-ch side are caused to light up in the same manner. The alternating lighting period for the R-ch and L-ch is 200 Hz.

Fig. 2-6

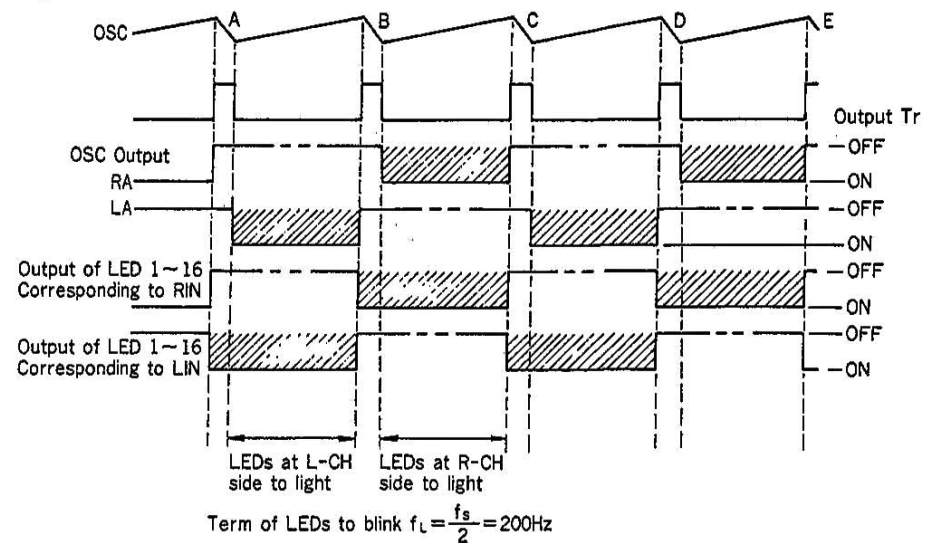

Fig. 2-7

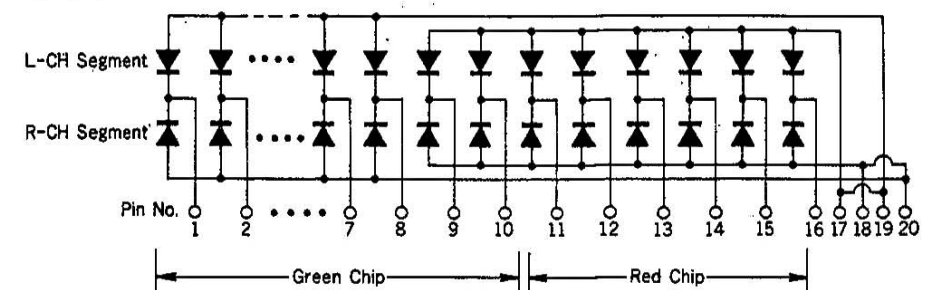
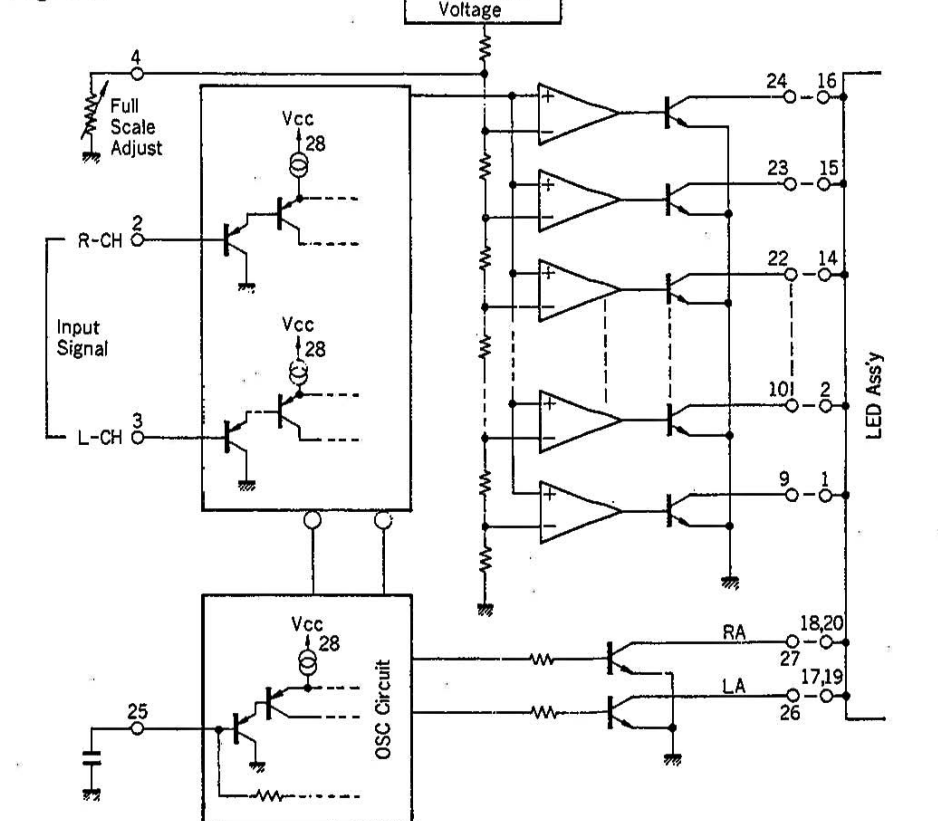

Fig. 2-8



3. ADJUSTMENTS

3-1. Adjustment of Electric Circuit

1. Tape Speed Adjustment

- Note: 1. Use Sansui Test Tape, SCT-S3K
(3 kHz signals are recorded on the tape).
2. Connections are shown in Fig. 3-1.

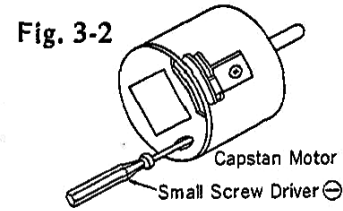
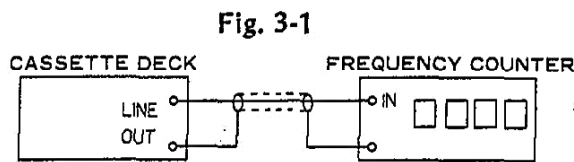

STEP	SUBJECT	INPUT SIGNAL	CHECK POINT	SETTING	ADJUST	ADJUST FOR	REMARKS
1.	TAPE SPEED ADJ.	Test Tape SCT-S3K	LINE OUT	Depress the PLAY button and playback the Test Tape, SCT-S3K	If not, turn semi-variable resistor as Fig. 3-2 until 3000 Hz $\pm 1.5\%$ is obtained.	3000 Hz $\pm 1.5\%$	Use small screw driver.

2. Playback Adjustment

- Note: 1. Before this adjustment, clean REC/P.B head surface.
2. Set the output level volume to be maximum.
3. For this adjustment, use Sansui Test Tape, SCT-F10KN, SCT-L400N and SCT-F1K.
4. Set the Dolby switch to be OFF.
5. Connections are shown below.

Note: Azimuth adjustment can be carried out from front side without removing head cover (See Fig. 4-8 on page 7)

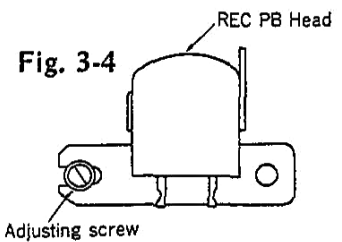
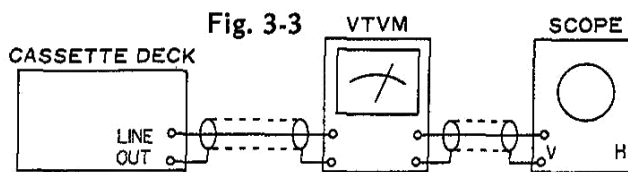

STEP	SUBJECT	INPUT SIGNAL	CHECK POINT	SETTING	ADJUST FOR	REMARKS
1.	REC/PB Head Adj.	SCT-F10KN	LINE OUT VTVM Scope	Depress the PLAY button and play back the Test Tape, SCT-F10KN.	Adjust the azimuth adjusting screw in Fig. 3-4 for the maximum reading on the VTVM on both channels.	After this adjustment, lock the screw with paint.
2.	Playback Level Adj.	SCT-L400N	Same as above	Set EQ SELECTOR to NORMAL (LH) position Depress the PLAY button and play back the Test Tape, SCT-L400N.	Adjust VR01 for L-CH and VR02 for R-CH for the reading of 500 mV on VTVM.	Set same level 500 mV ± 2 dB on both channels.
3.	High Frequency Equalization Check	SCT-F1K and SCT-F10KN	Same as above	Set EQ SELECTOR to NORMAL (LH) position Depress the PLAY button and play back the Test Tape, SCT-F1K and SCT-F10KN.	Confirm that the difference of output levels between SCT-F1K and SCT-F10KN is within ± 3 dB.	In playback of SCT-F10KN, set the EQ SELECTOR to HIGH (CrO ₂) position, then confirm the indication on VTVM drops down approximately 3 dB ~ 4 dB.

3. Recording Adjustment

1) Bias Adjustment

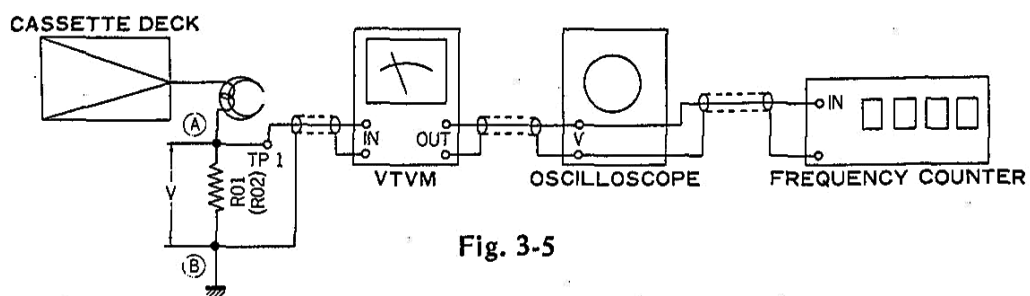

STEP	SUBJECT	INPUT SIGNAL	CHECK POINT	SETTING	ADJUST	REMARKS
1.	Recording Bias Adj.	SCT-SA	Voltage value between A and B of R01 & R02 (See Top View on page 9)	Depress REC, PLAY and PAUSE buttons. Set BIAS SELECTOR to HIGH (CrO ₂) position.	Adjust VR05 for L-CH and VR06 for R-CH for the reading of 6.0 mV between A and B in Fig. 3-5 on both channel.	VR05, VR06 See Top View on page 9.
				Set BIAS SELECTOR to NORMAL (LH) position.	Confirm the indication on VTVM shows 4.6 mV.	
				Set BIAS SELECTOR to Metal position.	Confirm the indication on VTVM shows 9.2 mV.	
2.	Bias Frequency	Same as above	C71, 72 Freq. counter	Set BIAS SELECTOR to NORMAL position.	Confirm that frequency counter shows 85 kHz ± 10 kHz.	C71, C72 ... See Top View on page 9

2) Rec Level & Frequency Response Adjustment

- Note: 1. Output Level Volume Maximum.
2. Connections are shown below.

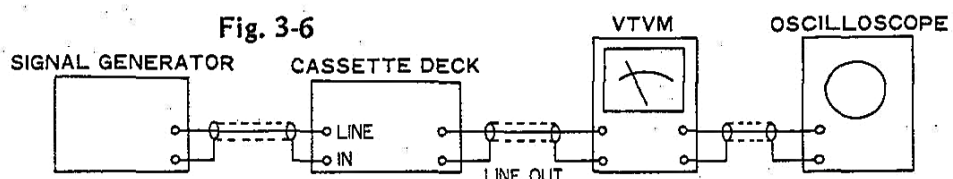

STEP	SUBJECT	INPUT SIGNAL	CHECK POINT	SETTING	ADJUST FOR	REMARKS
1.	REC Level Adj.	Use recording HIGH (CrO ₂) tape SCT-SA Feed 1 kHz, 70 mV (0 dB) from S.G into LINE IN.	LINE OUT VTVM Scope	Set BIAS & EQ SELECTOR to HIGH (CrO ₂) position. 1. Depress PAUSE, PLAY and REC button. 2. Adjust the Rec Level Volume for obtaining 300 mV on VTVM. 3. Push off the PAUSE button, then record the 1 kHz signal. 4. Play back the 1 kHz signal. 5. Confirm that the output levels on both channels are 300 mV ± 2 dB on VTVM.	1. If not, turn VR03 for L-CH and VR04 for R-CH until output level 300 mV ± 2 dB on both channel are obtained. 2. Repeat this REC Level adj. until the indication on VTVM will be 300 mV ± 2 dB.	VR03, VR04 (G-1242) See Top View on page 9
2.	Frequency Response Adj.	Feed 1 kHz 7 mV (-20 dB) and 10 kHz; 7 mV (-20 dB) from S.G. into LINE IN.	LINE OUT	Set BIAS & EQ SELECTOR to HIGH (CrO ₂) position. 1. Record the 1 kHz and 10 kHz signals from S.G. 2. Play back the 1 kHz and 10 kHz signals, then confirm that the difference of output levels between 1 kHz and 10 kHz are within 0 dB against that of 1 kHz.	1. If not, adjust VR05 for L-CH and VR06 for R-CH slightly until difference of output levels between 1 kHz and 10 kHz recorded are within 0 dB against that of 1 kHz.	As VR05 and VR06 are previously adjusted in step of Bias Adjustment, turn them slightly, if necessary.

4. Peak Level Meter Adjust

Note: Output Level Volume Max.

STEP	SUBJECT	INPUT SIGNAL	CHECK POINT	SETTING	ADJUST FOR	REMARKS
1.	Peak Level Meter Adj.	Feed 1 kHz 110 mV from S.G. into LINE IN SCT-SA	LINE OUT VTVM	1. Depress PAUSE, PLAY and REC button. 2. Adjust the Rec Level Volume for obtaining 470 mV on VTVM.	1. Light 0 dB indication of peak meter to adjust VR601 (L-CH) on G-1265. 2. Indication of 0 dB turns off when decreasing output level 0.2 dB from 470 mV by recording level volume.	Adjust VR601 (L-CH) on G-1265 at first then perform VR603 (R-CH) on G-1242.
2.	Filter 19 kHz 85 kHz Adj.	Feed 19 kHz 110 mV and 85 kHz 110 mV from S.G. into LINE IN.	LINE OUT VTVM	Depress PAUSE PLAY and REC button.	Make the output minimum to adjust white core (19 kHz) and black core (85 kHz) of LF01 (L-CH) and LF02 (R-CH)	LF01, LF02 (G-1242) See Top View on page 9

◇ Tape Selector Position

Tape Selector		REC	PLAY		
Tape		Bias/Equalizer	Equalizer		
FUJI	Super Range	metal	metal		
MAXELL	MX				
TDK	MA-R				
SCOTCH	Metafine				
SONY	METALLIC				
FUJI	Range 4X	high(CrO ₂)	high(CrO ₂)		
MAXELL	XL II				
TDK	SA				
SCOTCH	MASTER 70				
SONY	JHF				
BASF	SCR				
Tape Selector				REC	PLAY
Tape				Bias/Equalizer	Equalizer
SONY	Duad	normal(LH)	high(CrO ₂)		
BASF	FCR				
FUJI	Range-2	normal(LH)	normal(LH)		
	Range-4				
	Range-6				
MAXELL	UL				
	UD				
	XL I				
TDK	D				
	AD				
	OD				
Tape Selector		REC	PLAY		
Tape		Bias/Equalizer	Equalizer		
SCOTCH	TARTAN	normal(LH)	normal(LH)		
	CRYSTAL				
	MASTER 120				
SONY	AHF				
	BHF				
	CHF				
BASF	Low-Noise				
	LN				
	Super LH I				

◇ List of Sansui Test Tape

Name of test tape	Recorded Frequency	Description	Name of test tape	Recorded Frequency	Description
SCT-S3K	3KHz	Speed check, Wow & Flutter check	SCT-SA<HIGH(CrO ₂)>		Recording Bias Adjustment
SCT-L400N	400Hz	Playback level and VU meter level adjustment	SCT-LH<NORMAL(LH)>		REC/PB Level Adjustment
SCT-F1K	1KHz	High frequency equalization check	SCT-CS(Fe-Cr)		Frequency response check
SCT-F10KN	10KHz	REC/PB head adjustment	SCT-F40	40Hz	Playback Frequency response check

3-2. Mechanism Adjustment

1. Half Switch

Perform this adjustment when replacing half switch or in case that this switch doesn't turn on even if cassette half is set.

- 1) Confirm half switch turns on when half is set. If half switch does not turn on, adjust screw above the switch then reconfirm it switch can be turned on (See Fig. 3-7)

(To confirm with several maker's cassette half is recommended)

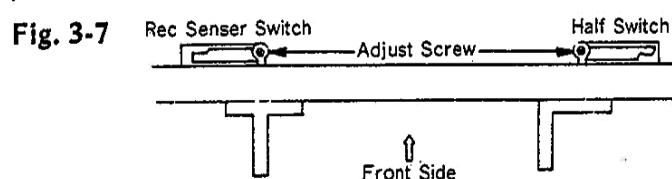

2. Rec Sensor Switch

- 1) Confirm rec sensor does not turn on when cassette half without accidental erasure preventing tab is set.
- 2) Confirm rec sensor turns on when cassette half with accidental erasure preventing tab is set.
- 3) If step 1, 2 are not normally functioned, adjust screw above rec sensor switch.

4. MAIN PARTS REPLACEMENT (See exploded view on page 8)

4-1. Capstan Motor

- 1) Remove bonnet.
- 2) Take off 2 springs hooked to the capstan motor mounting board.
- 3) Loosen 3 screws fixing motor mounting board.
- 4) Loosen 3 screws (No. 208) fixing motor to motor mounting board.

4-2. Reel Motor

- 1) Remove bonnet, front panel, and mechanism cover.
- 2) Loosen fixing screws (A), (B) (See Front View on page 9)
- 3) Remove cassette holder (upper nail), then loosen upper side motor mounting screw from the gap behind cassette holder (upper nail).
- 4) Take off the reel motor.

4-3. Supply Ass'y & Take-up Ass'y

- 1) Loosen a screw (No. 204) fixing reel hub ass'y shaft (No. 114) to supply/take up ass'y.
- 2) Remove supply/take-up ass'y after pulling out reel hub ass'y to this side.

Note: Pay attention not to loose 2 washers for mounting reel hub ass'y.

4-4. Rec Sensor Switch

Remove capstan motor, then loosen 2 screws fixing the switch from the mounting hole for capstan motor.

4-5. Capstan Belt & Capstan Flywheel

- 1) Remove mounting board fixing play plunger solenoid. (it is not necessary to take off plunger solenoid itself)
- 2) Pull out capstan flywheel from the gap after removing mounting board.
- 3) Remove a spring (No. 302) attached to head base driving plate.
- 4) Remove capstan belt.

4-6. Tension Arm Ass'y

- 1) Loosen 5 screws fixing mechanism chassis (No. 102) (Screws at the props supporting front chassis (No. 101) & mechanism chassis (No. 102))
- 2) Pull out the chassis toward inside.

3. Flywheel Thrust Screw

Perform this adjustment when replacing and removing capstan flywheel

- 1) Confirm the thrust (the play of front & rear direction) is within approximately 0.1 mm to move capstan in the front and rear direction. If thrust is too large, operation of capstan is not precisely performed therefore causing tape flow and if thrust is too little, the capstan rotation becomes rough.
- 2) In case, capstan rotation is rough, adjust flywheel thrust screw under the play plunger solenoid.

4. Pressure of Pinch Roller

The pressure of pinch roller can be adjusted by following two steps

- 1) If the pressure is weak, hook the end of spring to the hole outside (1).
- 2) If the pressure is strong, hook the end of spring to the hole inside (2).

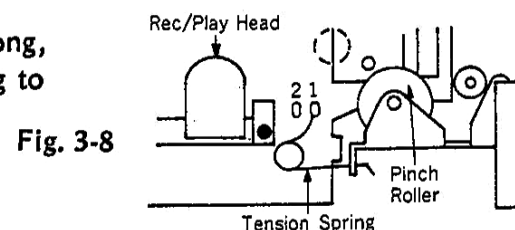

4-7. F.R. Idler

- 1) Remove head base (No. 105) by following procedure.
 - o Remove mechanism holder (right) (No. 157)
 - o Remove cassette holder (right side)
 - o Remove pinch roller ass'y (No. 108)
 - o Loosen a screw (No. 210) under play/rec head and remove head base fixing plate spring (No. 160) (Pay attention not to loose the steel ball (No. 226))
 - o Remove head base (Pay attention not to loose the steel ball under head base)
- 2) Remove capstan flywheel to follow step 4-5.
- 3) Remove E ring (No. 222) at the prop of FR idler.
- 4) Pull out FR idler to this side from the gap where head base is removed.

4-8. Head Cover (See Fig. 4-1, 4-2)

Perform this procedure when making azimuth adjustment or replacing head cover. Since props of head cover are fragile, please pay attention.

- 1) Open head cover about 1 cm (1/3 inch) and this angulation is important to remove it.
- 2) Lift the head cover keeping the angulation above. Putting forefinger in the 1 cm space (between head cover and mechanism cover) and lifting head cover to hold it by thumb and forefinger make easier to take off the first hooking (See Fig. 4-1)
- 3) Hold head cover close to mechanism cover, then lift it keeping this state till the possible point the head cover is lifted up.
- 4) By pressing both sides of head cover inward, remove head cover carefully. (See Fig. 4-2)
- 5) To attach head cover, perform step 3) inversely at first, then depress down after inserting to supporting groove.

Fig. 4-1

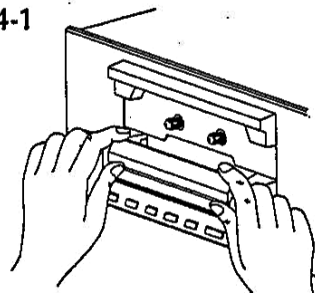
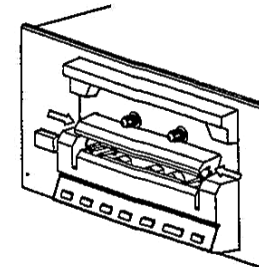

Fig. 4-2



* Performing procedures 1) ~ 3) make it possible to insert a screw driver to the hole for azimuth adjustment.

5. PARTS LIST OF MECHANISM Ass'y (Exploded View)

Parts List

Parts No.	Stock No.	Description
106	07527400	Wire Stopper
108	70603000	Pinch Roller Ass'y
109	70402200	Flywheel
(110, 164, 165, 222)	70603100	FR Idler Ass'y (No. 110,164,165,222 Included)
111	70900300	Tension Arm Ass'y
112	70603200	Supply/Take-up Ass'y
114	71501300	Reel Hub Ass'y
116	65010200	Cassette Holder, upper nail
125	70603300	Counter Idler Ass'y
126	65010500	Cassette Holder, right
127	65010600	Cassette Holder, left
128	07526400	Bracket Lever
129	60302200	Counter Belt (1)
130	60302400	Counter Belt (2)
131	66000200	Bushing, lamp holder
132	51604000	Flywheel Thrust Screw
135	07526500	Ring
141	71300100	Motor Pulley
142	07526600	Brake Lever
146	35010700	Insert Shaft
147	07526700	Rec Sensor Lever
150	85010800	Cassette Sensor Lever
152	54301400	Tape Counter
153	61401700	Back Tension Pulley
154	55007600	Motor Cushion
159	61401900	Motor Pulley
161	07526800	Take-up Belt
162	07526900	Capstan Belt
<Screw>		
201	08321100	Tapping Screw, 2.6 x 8
202	08322700	Tapping Screw, 2 x 12
203	08322300	Hex Socket Set Screw
204	08322900	Hex Socket Set Screw
205	51099110	Tapitite Screw, 3 x 16
206	08321200	Tapitite Screw, 3 x 5
207	08321300	SEMS A Screw, 2.6 x 4
208	08322800	SEMS B Screw, 2.6 x 7
209	08321400	SEMS A Screw, 2.6 x 8
210	08321500	SEMS A Screw, 2 x 5
211	08321700	SEMS A Screw, 3 x 10
212	08322100	SEMS A Screw, 3 x 6
213	08321600	SEMS A Screw, 2 x 6
214	08321500	Serrated Washer Head Screw, 2 x 5
215	08321900	Pan Head Screw, 2 x 5
216	08322000	Binding Head Screw, 3 x 5
217	08323400	Thrust Washer, 2.2 x 9.5 x 0.2
218	51804300	Thrust Washer, 2.1 x 5 x 0.25
219	51804400	Thrust Washer, 2.5 x 5 x 0.25
220	08323000	Plain Washer, 2.2 x 8 x 0.5
221	08323500	Thrust Washer, 2.4 x 6 x 0.5
222	08322500	E Ring, 1.5 x 0.4
223	51510020	E Ring, 2 x 0.4
224	08322600	E Ring, 2.5 x 0.4
225	51510040	E Ring, 3 x 0.6
226	65400300	Steel Ball, 2φ
<Spring>		
301	69011000	Head Adjust
302	69017300	Head Base
303	07527000	Play Plunger Reset
304	69017400	Brake
305	69017600	Pinch Roller
306	69017500	Changing Lever
307	69017700	Tension Pulley
308	69017800	Brake Lever
309	69017900	Limiter Plate
310	69018000	Lever Joint
311	69017200	Hold Lever
401	45360700	PLAY/REC Head
402	45260400	Erase Head
403	04008100	Illumination Lamp, 8 V 65 mA
404	43402600	Play Plunger
405	43402700	Plunger Solenoid, brake
406	43402800	Plunger Solenoid, hold
407	43207600	Reel Motor
408	11603100	Micro Switch
409	43207500	Capstan Motor
410	03614000	IC, DN6838

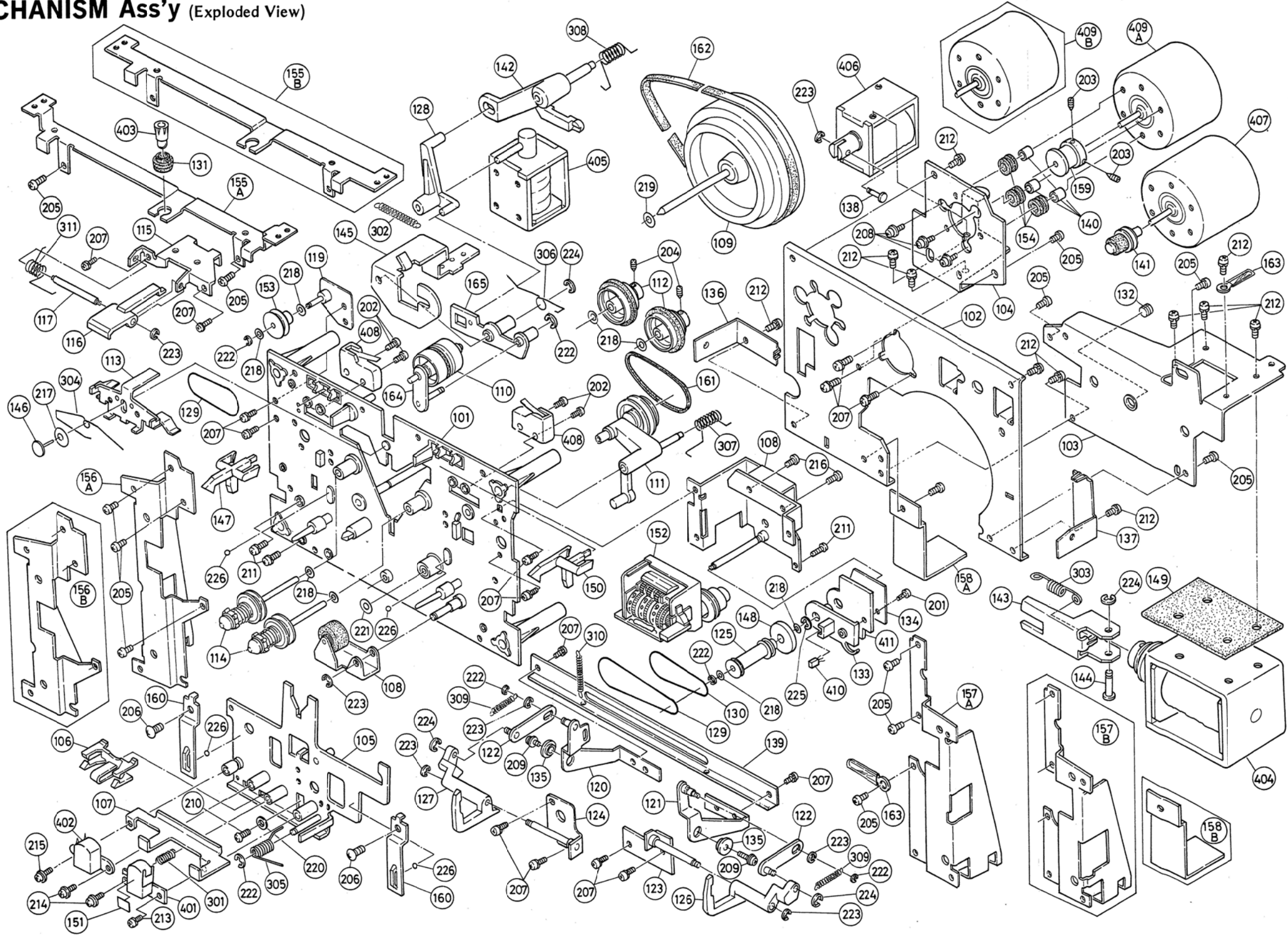

Abbreviations

1. Pan Head Tapping Screw ... PT Type	3. Pan Head Screw ... P Type	5. Pan Head SEMS B Screw ... PSB Type	7. Binding Head Screw ... B Type	9. Flat Countersunk Wood Screw ... FC Type	11. Hex. Socket Setscrew ... SC Type	13. Spring Washer ... S Type	15. Retaining Ring (E Washer) ... E Type
2. Washer Head Tapping Screw ... WT Type	4. Pan Head SEMS A Screw ... PSA Type	6. Binding Head SEMS F Screw ... BSF Type	8. Flat Countersunk Head Screw ... F Type	10. Round Head Wood Screw ... RH Type	12. Slot Type Setscrew ... SS Type	14. Plain Washer ... P Type	

*Though every part in included in mechanism ass'y is numbered in exploded view, part unlisted in the parts list are not supplied.

6. OTHER PARTS

6-1. Front View

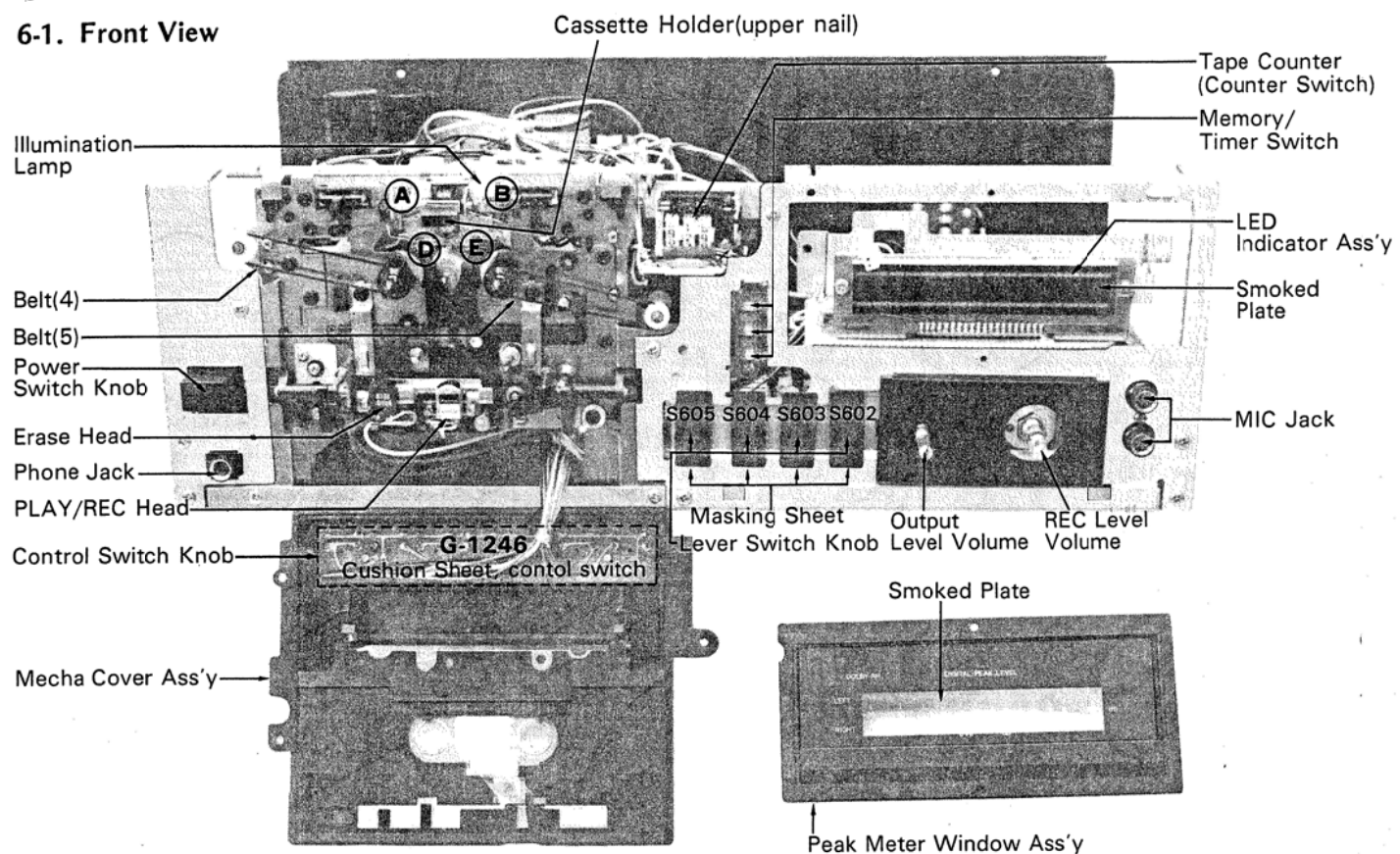

6-3. Side View

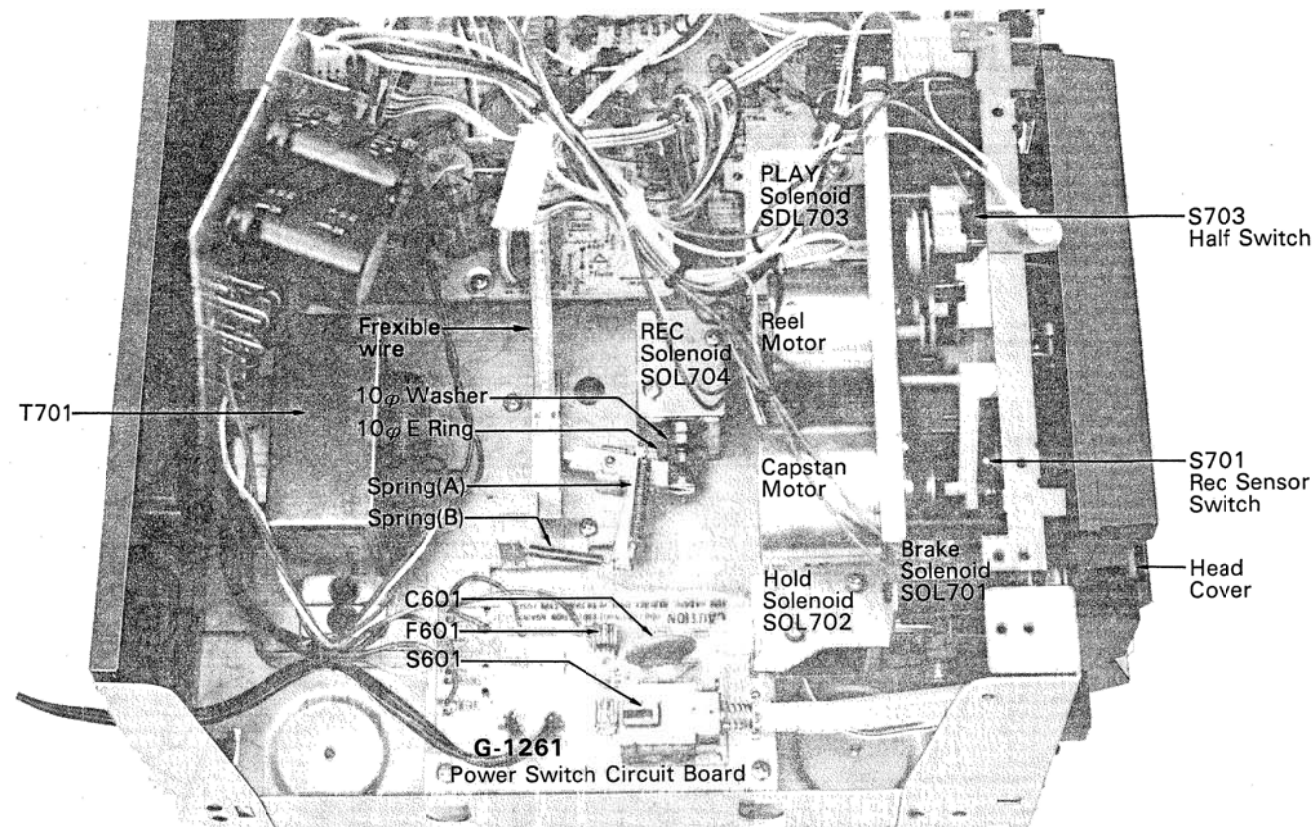

6-2. Top View

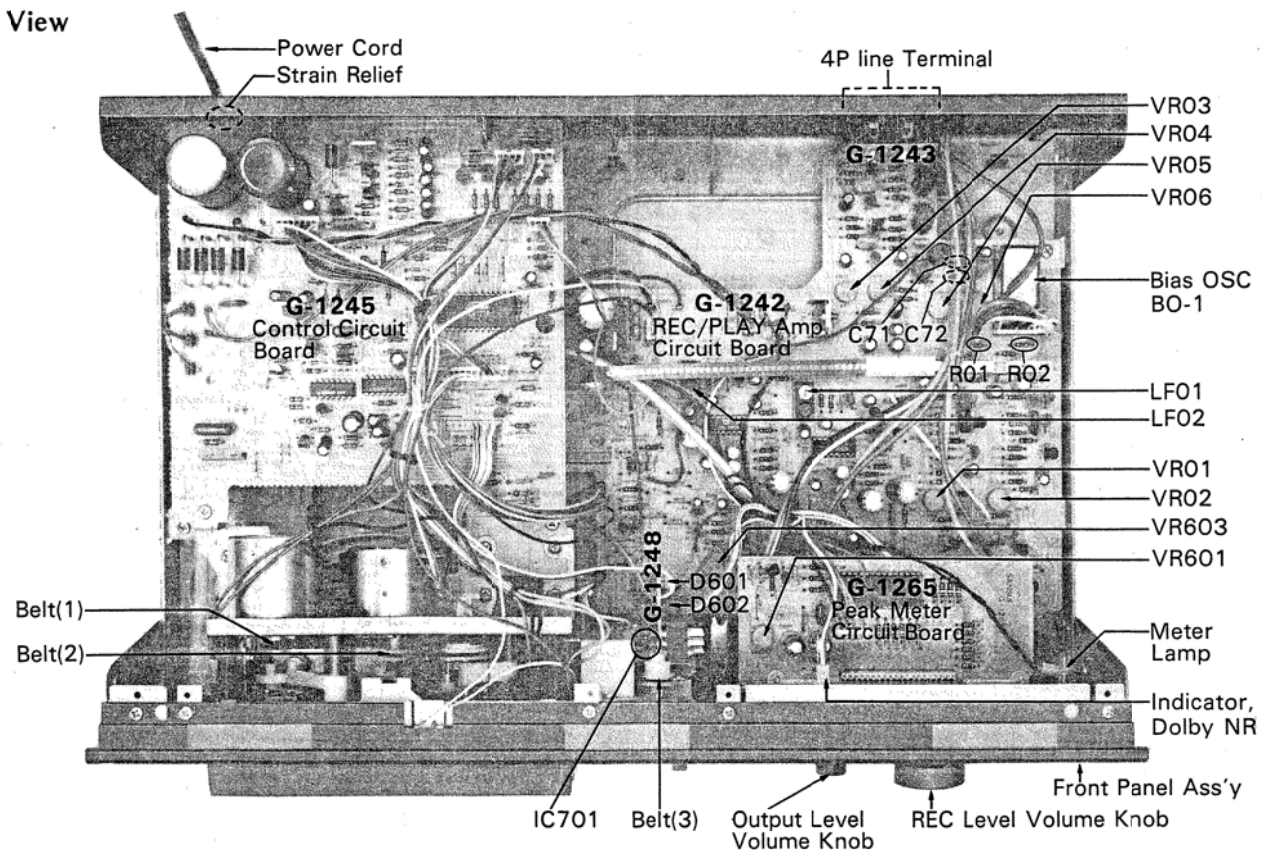

Parts List <Front View/Top View/Side View>

Parts No.	Stock No.	Description	Parts No.	Stock No.	Description
	45360600	PLAY/REC Head		55007100	Cushion Sheet, control switch
	45260400	Erase Head		24305400	Phone Jack
	43207500	Capstan Motor		70004400	Mecha Cover Ass'y B
	43207600	Reel Motor		70004300	Mecha Cover Ass'y S
SOL701	43402700	Plunger Solenoid, brake		11398000	Memory/Timer Switch
SOL702	43402800	Plunger Solenoid, hold	S 602	11721000	Dolby NR Switch
SOL703	43402600	Plunger Solenoid, play	S 603	11721200	Tape Selector Switch, equalizer
SOL704	43402500	Plunger Solenoid, rec	S 604	11721000	Tape Selector Switch, bias
S 701	11603100	Rec Sensor Switch	S 605	11720900	Rec Muting Switch
S 703	11603100	Half Switch	IC 701	03614000	IC DN6838 for Auto Stop
	07526900	Belt (1), capstan belt		55102210	Masking Sheet B
	07526800	Belt (2), take-up belt		55102310	Masking Sheet S
	60302400	Belt (3), counter belt		10156400	Output Level Volume, 10kΩ x 2
	60302200	Belt (4), back tension belt		10250400	Rec Level Volume, 50kΩ A x 2
	60302200	Belt (5), counter belt		24305300	Mic Jack
	54301400	Tape Counter (Lamp, Switch)		03613400	LED Indicator Ass'y, SEL8809
	38004700	Power Cord		54401300	Smoked Plate, LED indicator . . . B
	39106000	Strain Relief, power cord		54401310	Smoked Plate, LED indicator . . . S
	22005800	4P Line Terminal		54505600	Peak Meter Window Ass'y
	71000800	Knob, power switch B		(54505800)	Scale Glass, peak meter window ass'y)
	71000900	Knob, power switch S	T 701	40032700	Power Transformer Ass'y
	53206600	Knob, Rec/Play/REW/Pause/Tape Lead IN Control Switch		50502700	Head Cover
	53206500	Knob, stop control switch	C 601	00290400	0.01μF 50V E.C.
	53206110	Knob, lever switch B	S 601	71000800	Knob, power switch B
	53206210	Knob, lever switch S	S 601	71000900	Knob, power switch S
	53105200	Knob, output level B	F 601	04322300	AC Fuse 1.5A
	53106410	Knob, output level S		65017100	Spring (A), rec solenoid
	53105300	Knob, rec level volume (left) . . . B		65017000	Spring (B), rec solenoid
	53106210	Knob, rec level volume (left) . . . S		50000900	Bonnet B
	53105400	Knob, rec level volume (right) . . B		57402710	Bonnet S
	53106310	Knob, rec level volume (right) . . B		55073500	Leg
	70004020	Front Panel Ass'y B		04007400	Meter Lamp, peak indicator,
	70003420	Front Panel Ass'y S			12V 100 mA
	52605410	Front Mecha Glass		03193300	Indicator, Dolby, NR
	55102910	Cushion Sheet		60560500	Flexible wire
	54400900	Counter Lens			
	71000600	Push Knob Ass'y, function switch			

Note:
 Since there are SC-3330 (Black Model) & SC-3300 (Silver Model) in the parts list above, please pay attention when ordering parts.
 Parts marked (B) in parts list for SC-3330 only
 Parts marked (S) in parts list for SC-3300 only

7. SCHEMATIC DIAGRAM 7-1. Amplifier Section

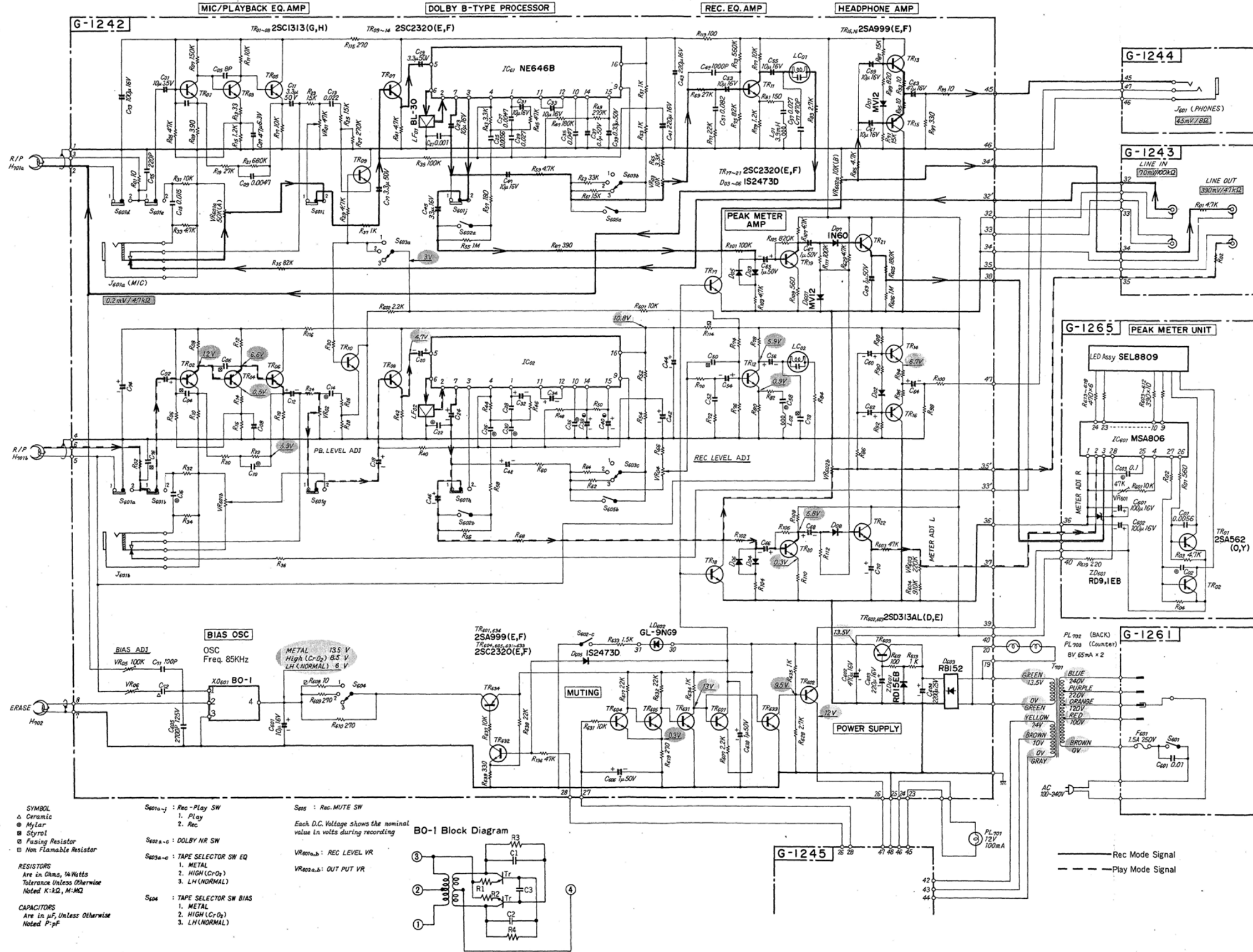

1

2

3

4

5

7-2. Control Section

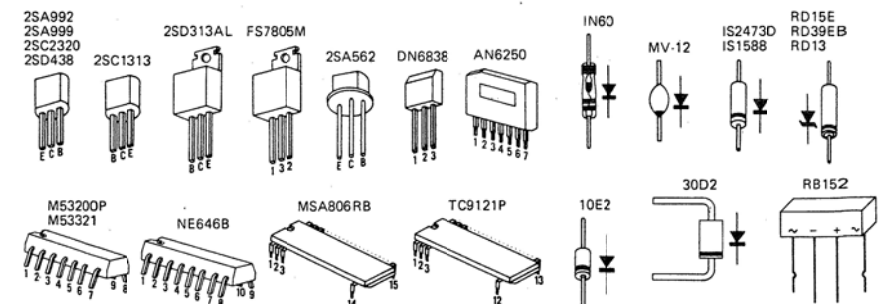
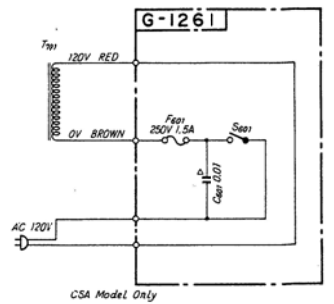
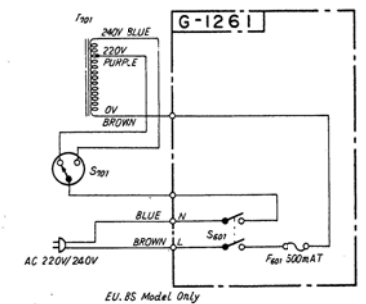
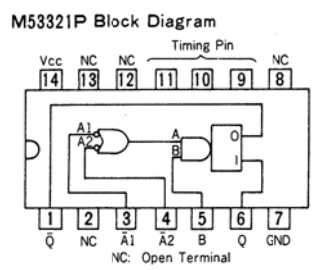
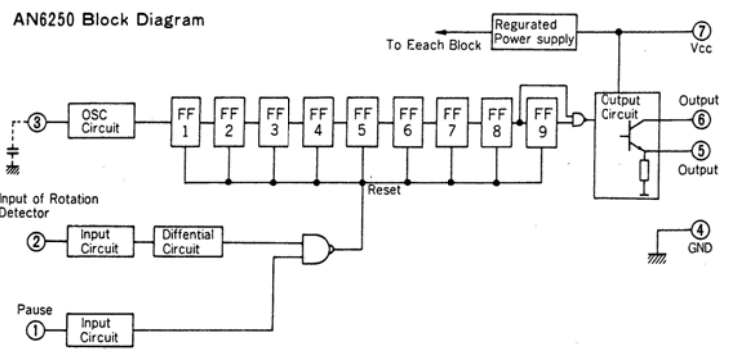
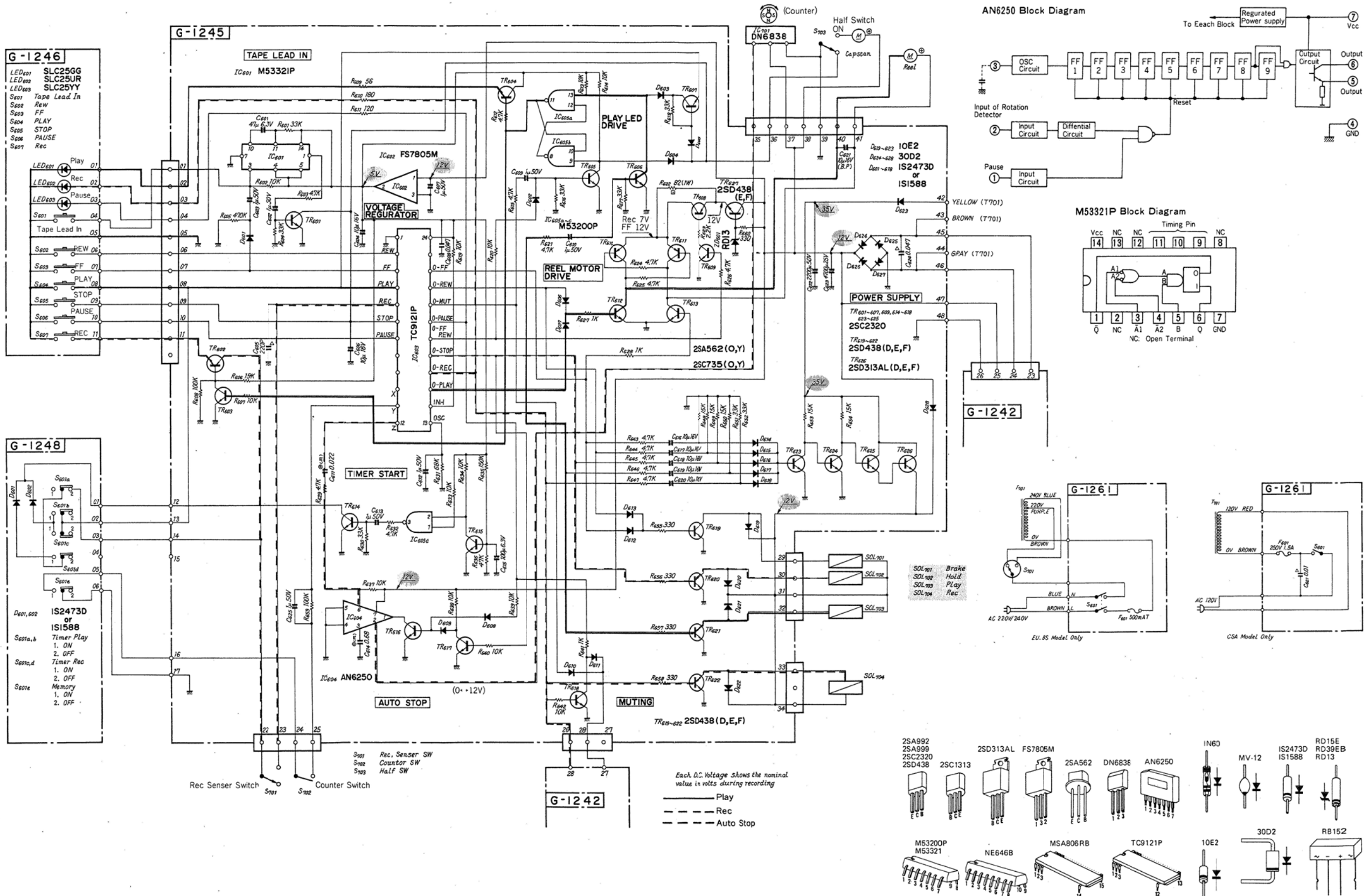

Each D.C. Voltage shows the nominal value in volts during recording

— Play
 - - - Rec
 - · - Auto Stop

1
 2
 3
 4
 5

8. PARTS LOCATION & PARTS LIST

8-1. G-1245 Control Circuit Board (Stock No.76401201)

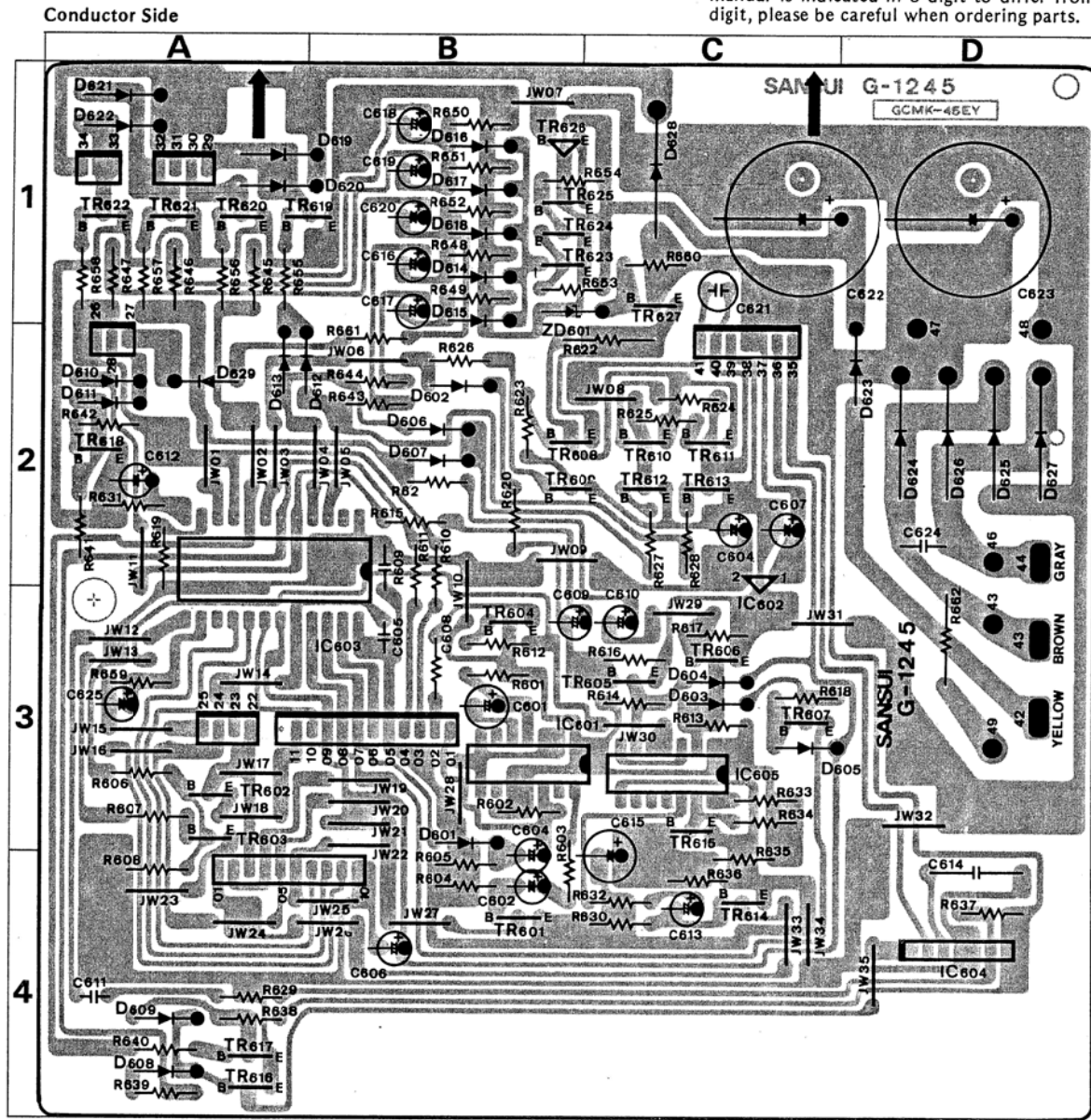

Parts List

Parts No.	Stock No.	Description	Position	Parts No.	Stock No.	Description	Position	Parts No.	Stock No.	Description	Position
•Transistor											
TR601 ~ 03	03068301, 2	2SC2320 E, F	3A, AB	TR619 ~ 22	03085200, 1	2SD438 D, E	1A	IC 604	03611000	AN-6250	4D
TR604 ~ 07	03068301, 2	2SC2320 E, F	3B, C	TR623 ~ 25	03068301, 2	2SC2320 E, F	1B	IC 605	03611400	M-53200P	3C
TR608	03002200, 1	2SA562 O, Y	2B	TR626	03083901, 2	2SD313AL D, E	1B	•Diode			
TR609	03068301, 2	2SC2320 E, F	2B, C								
TR610, 611	03002200, 1	2SA562 O, Y	2C	D 601 ~ 18	03111600	1S2473D	2, 3B				
TR612, 613	03056400, 1	2SC735 O, Y	2C	D 619 ~ 23	03117700	10E-2	1A, 2D				
TR614 ~ 18	03068301, 2	2SC2320 E, F	3A, C	D 624 ~ 28	03115300	30D2	1C, 2D				

•Abbreviations

C.R. Carbon Resistor	E.L. Low Leak Electrolytic Capacitor
S.R. Solid Resistor	E.B. Bi-Polar Electrolytic Capacitor
Ce.R. Cement Resistor	E.BL. Low Leak Bi-Polar Electrolytic Capacitor
M.R. Metal Film Resistor	Ta.C. Tantalum Capacitor
F.R. Fusing Resistor	F.C. Film Capacitor
N.I.R. Non-Inflammable Resistor	M.P. Metalized Paper Capacitor
C.C. Ceramic Capacitor	P.C. Polystyrene Capacitor
C.T. Ceramic Capacitor, Temperature Compensation	G.C. Gimmic Capacitor
E.C. Electrolytic Capacitor	

•Since some of capacitors and resistors are omitted from parts lists in this Service Manual, refer to the Common Parts List for capacitors & resistors which was appended previously to each Sansui Manual.

•As the stock number in the parts list on this service manual is indicated in 8 digit to differ from ordinary 7 digit, please be careful when ordering parts.

8-2. G-1242 Play & Rec Amp. Circuit Board (Stock No.76201701)

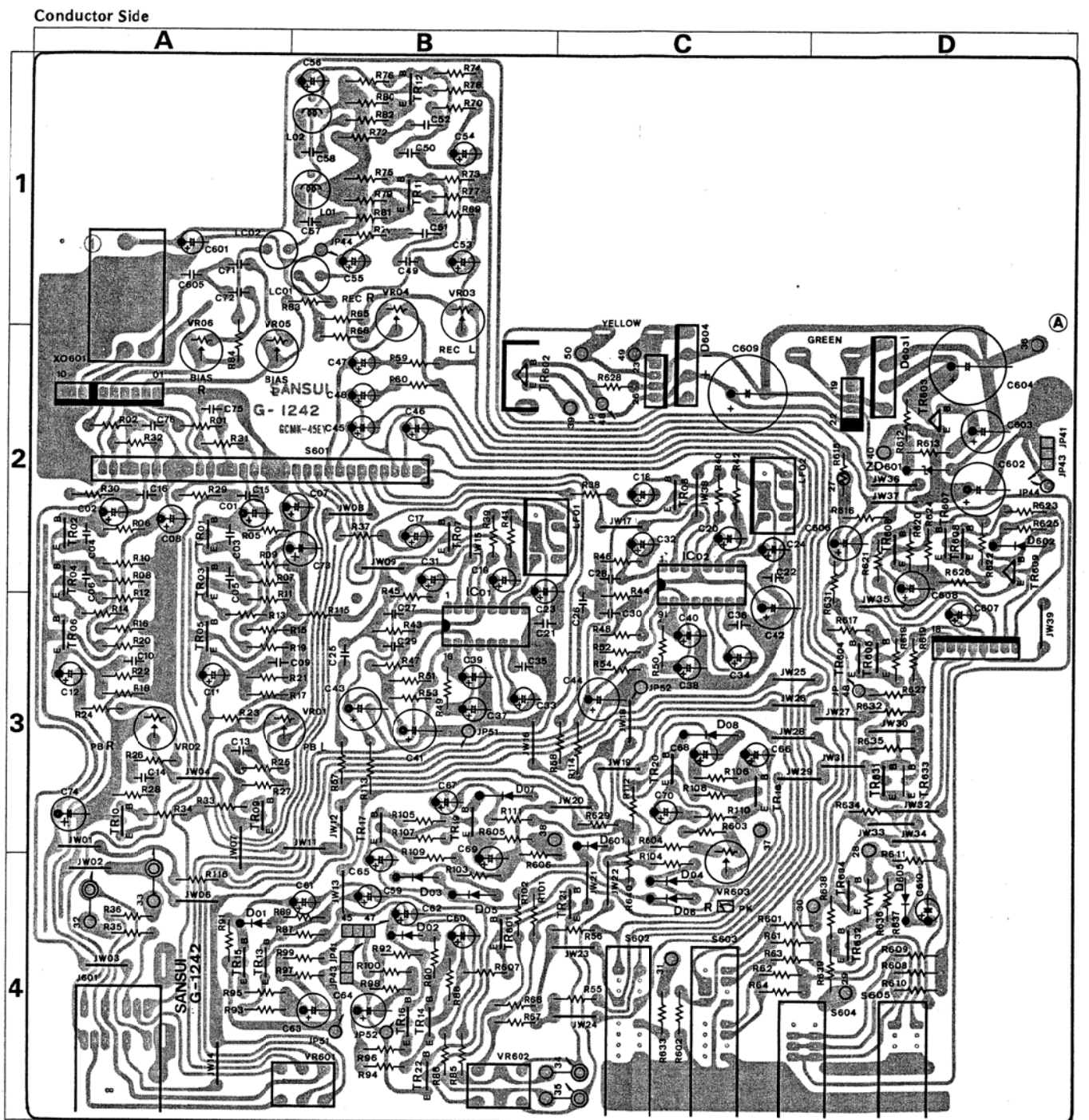

Parts List

Parts No.	Stock No.	Description	Position	Parts No.	Stock No.	Description	Position	Parts No.	Stock No.	Description	Position
•Transistor											
TR01 ~ 08	0306701, 2	2SC1313 G, H	2A, B, C	D 07, 08	03117800	1N60TF-1	3, BC	VR03, 04	10351300	10kΩ B, Rec Level Volume	1B
TR09 ~ 14	03068301, 2	2SC2320 E, F	1B, 4A	D 01	03401500	MV-12	3C	VR05, 06	10351900	100kΩ B, Bias Volume	2A
TR15, 16	03012700, 1	2SA999 E, F	4, AB	D 603	03117000	RB-152	2D	VR601	10250400, 1	50kΩ A, Rec Level Volume	4B
TR17 ~ 22	03068301, 2	2SC2320 E, F	3, 4B, C	•Zener Diode							
TR601	03012700, 1	2SA999 E, F	4B	ZD601	03179200	RD15E-B	2D	VR602	10156400, 1	10kΩ B x 2, Output Level Volume	4B
TR602, 603	03083901, 2	2SD313AL D, E	2, 8D	•LED							
TR604, 605	03068301, 2	2SC2320 E, F	3, 4D	LED602	03193300	GL9NG9		S 601	11104000	Rec/Play Switch	2A
TR631 ~ 33	03068301, 2	2SC2320 E, F	3, 4D	L 01, 02	49005500	3.9μH Inductor	1B	S 602	11721100	Dolby NR Switch	4C
TR634	03012700, 1	2SA999 E, F	4D	LC01, 02	42904400	Trap Coil	1, AB	S 603	11721200	Tape Selector Switch (EQ)	4C
•IC											
IC 01, 02	03613600	NE646B	2C, 3B	LF01, 02	09106300	BL-30HA, Low Pass Filter	2, BC	S 604	11721000	Tape Selector Switch (Bias)	4C
D 01, 02	03401500	MV-12	4, AB	•Diode							
D 03 ~ 06	03117600	1S2473D	4, BC	D 01, 02	03401500	MV-12	4, AB	S 605	11720900	Rec Muting Switch	4D
•Diode											
D 01, 02	03401500	MV-12	4, AB	VR01, 02	10351700	47kΩ B, Play/Rec Volume	3A	J 601	24305300	Mic Jack	4A
D 03 ~ 06	03117600	1S2473D	4, BC	•Composite Parts							
X0601 08250400 Composite Parts 1A											